

# Operation and Maintenance Manual

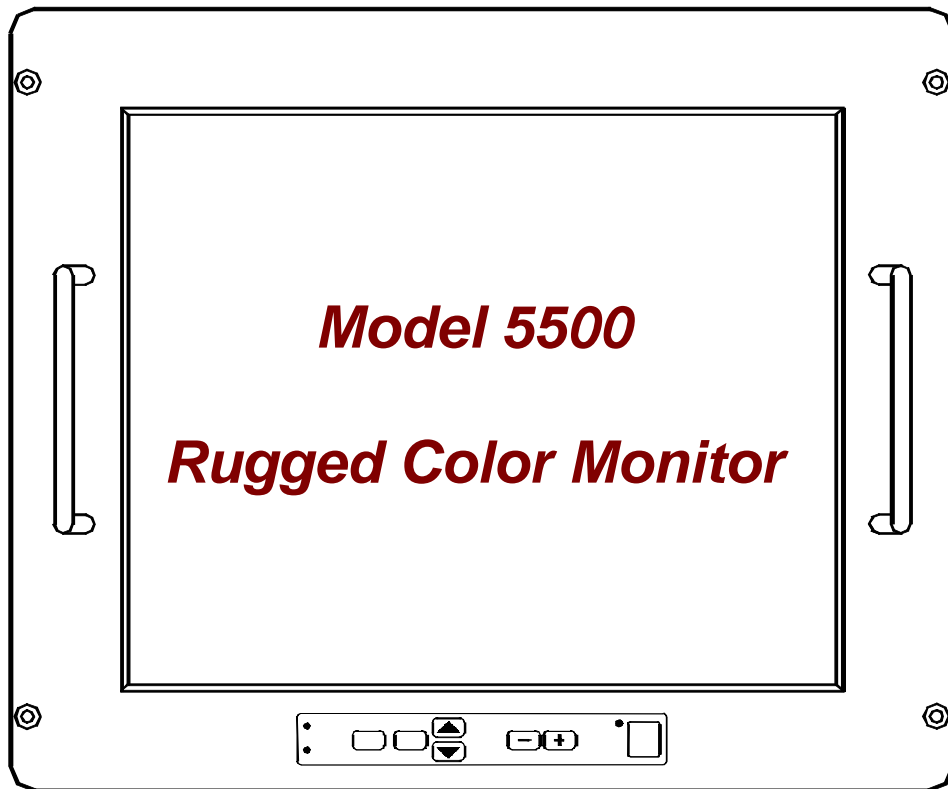

DataMetrics Corporation  
1717 Diplomacy Row  
Orlando, FL 32809



This manual is intended to function as an example ONLY and does not represent all configurations and options for this product.

## **Data Rights Provisions**

THE INFORMATION CONTAINED IN THIS MANUAL IS SUPPLIED WITH LIMITED RIGHTS ONLY. DATA SHALL NOT, WITHOUT THE WRITTEN PERMISSION OF THE CONTRACTOR, BE EITHER (A) USED, RELEASED, OR DISCLOSED IN WHOLE OR IN PART OUTSIDE THE GOVERNMENT, (B) USED IN WHOLE OR IN PART BY THE GOVERNMENT FOR MANUFACTURE OR, IN THE CASE OF COMPUTER SOFTWARE DOCUMENTATION, FOR PREPARING THE SAME OR SIMILAR COMPUTER SOFTWARE, OR (C) USED BY A PARTY OTHER THAN THE GOVERNMENT, EXCEPT FOR: (1) EMERGENCY REPAIR OR OVERHAUL WORK ONLY, BY OR FOR THE GOVERNMENT, WHERE THE ITEM OR PROCESS CONCERNED IS NOT OTHERWISE REASONABLY AVAILABLE TO ENABLE TIMELY PERFORMANCE OF THE WORK, PROVIDED THAT THE RELEASE OR DISCLOSURE HEREOF OUTSIDE THE GOVERNMENT SHALL BE MADE SUBJECT TO A PROHIBITION AGAINST FURTHER USE, RELEASE OR DISCLOSURE; OR (2) RELEASE TO A FOREIGN GOVERNMENT, AS THE INTEREST OF THE UNITED STATES MAY REQUIRE, ONLY FOR INFORMATION OR EVALUATION WITHIN SUCH GOVERNMENT OR THE CONDITIONS OF (1) ABOVE. THIS STATEMENT SHALL BE INCLUDED ON ANY REPRODUCTION HEREOF.

**RECORD OF CHANGES**

Date	Revision	Description of Change
060530	-	Initial release

## Contents

<b>1</b>	<b>CONFIGURATION.....</b>	<b>1</b>
<b>2</b>	<b>GENERAL INFORMATION .....</b>	<b>2</b>
2.1	Applicable Documents.....	2
2.2	Equipment Description .....	2
2.3	Specifications.....	2
<b>3</b>	<b>INSTALLATION.....</b>	<b>6</b>
3.1	Introduction .....	6
3.2	Unpacking .....	6
3.3	Chassis Installation.....	6
3.4	External Cable Installation.....	6
<b>4</b>	<b>OPERATION.....</b>	<b>9</b>
4.1	Introduction .....	9
4.2	Controls and Indicators .....	9
4.3	Power Up .....	10
4.4	Setup .....	10
4.4.1	Image Adjustment.....	10
4.4.2	Navigating Menus.....	10
4.4.3	On Screen Display Menus .....	10
4.4.3.1	Brightness and Contrast.....	11
4.4.3.2	Color Temperature.....	11
4.4.3.3	Frequency and Phase .....	11
4.4.3.4	Status .....	12
4.4.3.5	Position .....	12
4.4.3.6	Picture in Picture Menu .....	12
4.4.3.6.1	PIP Size .....	12
4.4.3.6.2	PIP Source.....	12
4.4.3.6.3	Horizontal Position.....	13
4.4.3.6.4	Vertical Position.....	13
4.4.3.6.5	Advanced PIP Settings .....	13
4.4.3.7	Graphic Scaling Modes .....	13
4.4.3.7.1	One to One .....	13
4.4.3.7.2	Fill Screen .....	13
4.4.3.7.3	Fill to Aspect Ratio .....	13

- 4.4.3.7.4 Nonlinear Scaling Mode..... 14
- 4.4.3.8 Language Menu ..... 14
- 4.4.3.9 Video Source ..... 14
- 4.4.3.10 Utilities ..... 14
  - 4.4.3.10.1 User Setting ..... 15
    - 4.4.3.10.1.1 Display Timeout ..... 15
    - 4.4.3.10.1.2 DPMS ..... 15
    - 4.4.3.10.1.3 Display Input ..... 15
    - 4.4.3.10.1.4 Auto Source Select ..... 15
    - 4.4.3.10.1.5 Gamma ..... 15
  - 4.4.3.10.2 OSD Setting ..... 15
    - 4.4.3.10.2.1 OSD Horizontal and Vertical Position ..... 15
    - 4.4.3.10.2.2 OSD Background ..... 15
    - 4.4.3.10.2.3 OSD Rotate ..... 15
  - 4.4.3.10.3 Freeze Frame ..... 16
  - 4.4.3.10.4 Zoom ..... 16
  - 4.4.3.10.5 Direct Access #1 ..... 16
  - 4.4.3.10.6 Direct Access #2 ..... 16
  - 4.4.3.10.7 Display Orientation ..... 16
  - 4.4.3.10.8 Calibrate RGB Gain ..... 16
  - 4.4.3.10.9 Load Factory Defaults ..... 16
- 4.4.3.11 Volume ..... 16
- 4.4.3.12 Exit ..... 16
  
- 5 FUNCTIONAL DESCRIPTION .....17**
  - 5.1 Introduction ..... 17**
    - 5.1.1 Power Distribution..... 17
    - 5.1.2 Video Display System ..... 17
      - 5.1.2.1 Display Controller ..... 17
      - 5.1.2.2 LVDS Board ..... 17
      - 5.1.2.3 Display Panel..... 17
      - 5.1.2.4 Inverter..... 17
    - 5.1.3 Control Panel ..... 19
    - 5.1.4 Fault Monitoring and Heater Subsystem ..... 19
    - 5.1.5 Optional Features..... 19
      - 5.1.5.1 Input Power..... 19
      - 5.1.5.2 Single-Pole Circuit Breaker ..... 19
  
- 6 MAINTENANCE.....20**
  - 6.1 Introduction ..... 20**
  - 6.2 Tools and Support Equipment ..... 20**
  - 6.3 Periodic Maintenance..... 20**
    - 6.3.1 Display Adjustments..... 20
    - 6.3.2 Cleaning..... 20
  - 6.4 Troubleshooting ..... 20**
  - 6.5 Storage and Transportation ..... 20**



### Figures

Figure 3-1. Chassis Installation Configuration..... 7  
Figure 3-2. Rear Panel ..... 8  
Figure 4-1. Control Panel ..... 9  
Figure 5-1. Chassis Interconnections..... 18

### Tables

Table 1-1. System Configuration..... 1  
Table 1-2. External Interfaces ..... 1  
Table 1-3. Mating Connector..... 1  
Table 2-1. Physical Specifications..... 2  
Table 2-2. Electrical Specifications ..... 3  
Table 2-3. Display Specifications..... 4  
Table 2-4. Environmental Specifications ..... 5  
Table 4-1. Controls and Indicators ..... 9  
Table 6-1. Troubleshooting ..... 21  
Table 6-1. Troubleshooting ..... 21

# 1 CONFIGURATION

This chapter defines the configuration of a specific Model 5500 Color Monitor. Information is provided in Table 1-1 through Table 1-3 concerning system configuration, external interfaces, and external cables.

**Table 1-1. System Configuration**

Characteristic	Description
Top assembly part number	
Input power	115-220 VAC Standard (28VDC Optional)
Circuit breaker	15A SPST
Heater option	Optional

**Table 1-2. External Interfaces**

Function	Pin	Signal
R,G,B,H,V	BNC	Analog component
Power	D38999/20WD5PN	85-264 VAC power

**Table 1-3. Mating Connector**

Description	Part No.
Conn. Series III, Plug with Sockets	
Strain Relief, Series III, Connector	



## 2 GENERAL INFORMATION

This manual provides information and instructions required for the operation and maintenance of the ruggedized Model 5500 Color Monitor manufactured by DataMetrics Corporation (DMC).

### 2.1 Applicable Documents

#### Military Specifications

MIL-E-5400T General Specification for Aerospace, Electronic Equipment

#### Military Standards

MIL-STD-167 Mechanical Vibrations of Shipboard Equipment

MIL-STD-461 Requirements for the Control of Electromagnetic Interference Characteristics of Subsystems and Equipment

MIL-STD-810E Environmental Engineering Considerations and Laboratory Tests

#### Commercial Standards

### 2.2 Equipment Description

The DMC Model 5500 Color Monitor is a ruggedized, 19-inch active matrix liquid crystal display (LCD) designed for use in ground mobile, shipboard, and airborne environments. The equipment is packaged using environmental management techniques that protect internal components from shock, vibration, temperature extremes, and EMI/RFI. The chassis is designed for installation in a standard 19-inch equipment rack.

The Model 5500 incorporates a true-color thin-film transistor (TFT) LCD with automatic sync detection and 120-degree viewing angle. An EMI shield with integral heater is included to facilitate low temperature operation.

### 2.3 Specifications

Model 5500 specifications are defined in Tables 2-1 through 2-4.

**Table 2-1. Physical Specifications**

Characteristic	Description
Dimensions	15.75" high x 19.00" wide x 4.12" deep <sup>(1)</sup>
Weight	28 lb

<sup>(1)</sup> Excluding handles and optional components.

**Table 2-2. Electrical Specifications**

Characteristic	Description
Input Voltage 115-220 VAC	85 - 264 VAC
Input Frequency 115-220 VAC	47 to 440 Hz
Power Consumption	
Nominal	60 W
Power Save Mode	8 W
Heaters Activated	165 W

**Table 2-3. Display Specifications**

Characteristic	Description
Screen Dimensions	
Area	14.82 x 11.85 inches
Diagonal	19 inches
Color	8-bit, 16 M colors
Resolution	1280 x 1024 pixels, VGA to SXGA
Viewing Angle	± 60°C vertical and horizontal from center
Aspect Ratio	5:4
White Surface Luminance	400 cd/m <sup>2</sup> (maximum)
Contrast Ratio	450:1 (typical)
Response Time	
Rise Time (black to white)	17 ms typical, 30 ms maximum
Decay Time (white to black)	13 ms typical, 20 ms maximum
Signal Input	
Standard	R, G, B, H/HV, V analog
Optional	PAL, NTSC, S-Video
Synchronization	Composite, horizontal and vertical, or SOG
Front Filter	Tempered glass

**Table 2-4. Environmental Specifications**

Characteristic	Description
Temperature Operating Non-operating	-40 to 55°C -40 to 70°C
Relative humidity (including condensing)	Up to 100%
Altitude Operating Non-operating	Up to 25,000 feet Up to 45,000 feet
Vibration Shipboard	MIL-STD-167-1
Shock	30 g, 11 ms on each axis, ½ sine
Inclination	Unit will operate in any orientation
EMI/EMC	MIL-STD-461, Methods CE01, CE02, CE03, CS01, CS02, CS06, RE01, RS01, and RS03.
Magnetic Field	No damage from 20 oersted field
Drip Proof	Unit is environmentally sealed

## 3 INSTALLATION

### 3.1 Introduction

This chapter provides information and instructions required for installation of the Model 5500 Monitor. Information is included concerning rack mounting and connection of external cabling.

### 3.2 Unpacking

Carefully remove the unit from the shipping container. Inspect the unit for any evidence of damage. Retain packing materials for future use.

### 3.3 Chassis Installation

The monitor chassis is designed to mount on the front rails of a standard 19-inch equipment rack. The monitor may be installed on other platforms that have compatible mounting provisions. Chassis installation dimensions are shown in Figure 3-1.

- a. Position the monitor at the front of the rack with the four mounting holes aligned on a 12.75-inch vertical hole pattern. Select a mounting height that provides a desirable viewing angle.
- b. Secure the monitor to the rack with four fasteners and the appropriate locking hardware.

### 3.4 External Cable Installation

All external interfaces for the monitor are located at the rear panel (Figure 3-2). External connector assignments for the delivered configuration are identified in Chapter 1. Perform the following steps to connect external cabling.

- a. Connect the system ground cable to the ground stud on the rear panel.
- b. Connect the video source to the R,G,B,H,V connectors.
- c. Connect the power cable to the prime power connector on the rear panel.

#### CAUTION

VERIFY THAT THE POWER SOURCE CONFORMS TO THAT SPECIFIED IN TABLE 1-1 FOR THE DELIVERED SYSTEM CONFIGURATION.

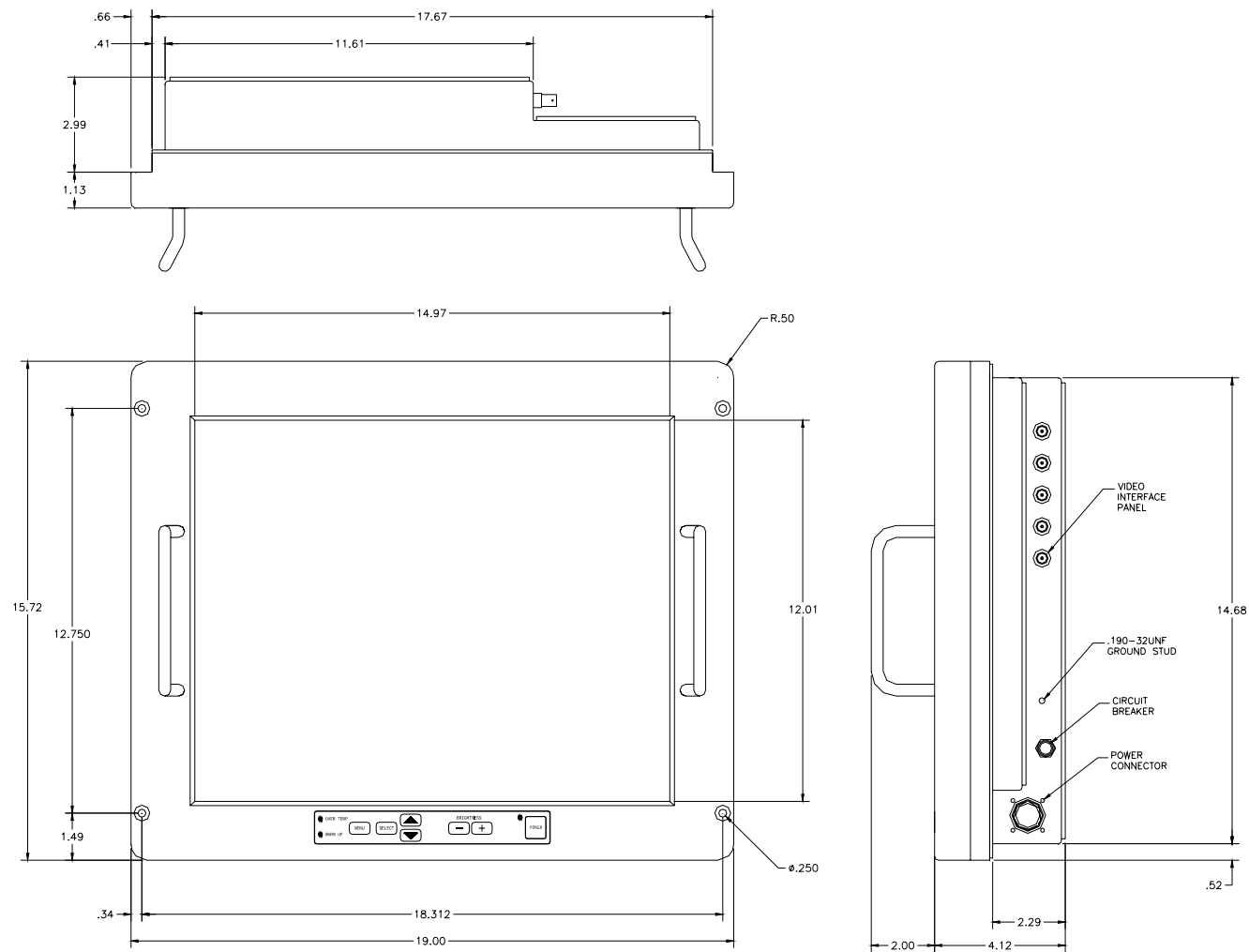
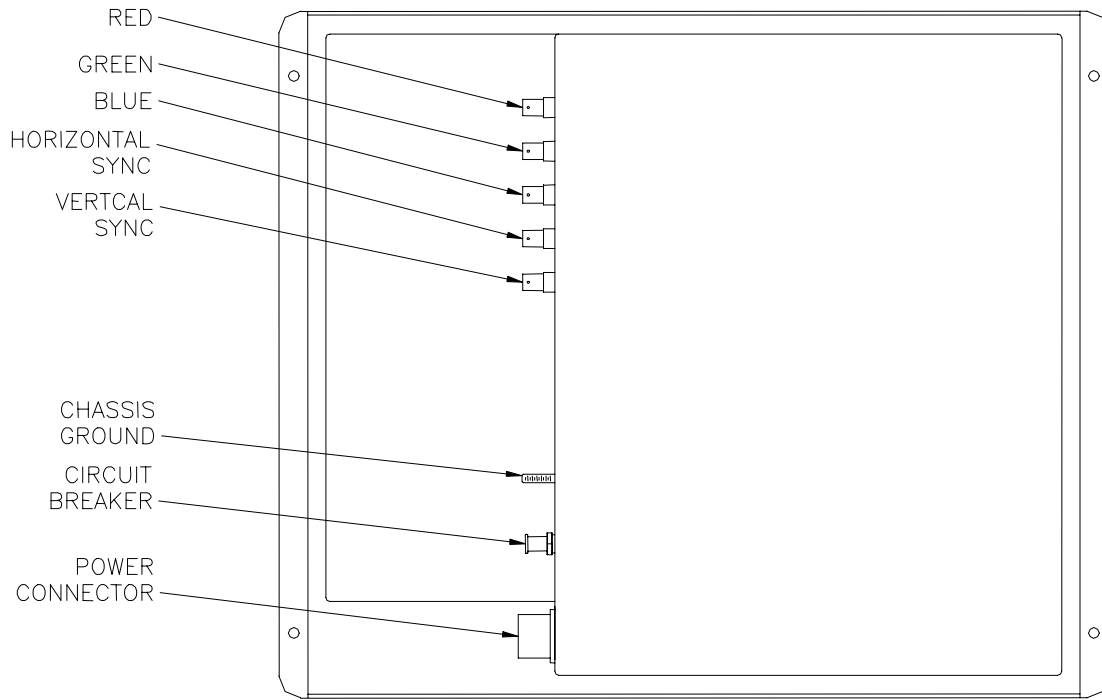

Figure 3-1. Chassis Installation Configuration



**Figure 3-2. Rear Panel**

## 4 OPERATION

### 4.1 Introduction

This chapter provides information concerning set up and configuration options for the Model 5500 monitor. Before the unit is powered up for the first time, verify that the installation procedures defined in Chapter 3 have been performed.

### 4.2 Controls and Indicators

All controls and indicators required for operation of the Model 5500 monitor are located on the control panel (Figure 4-1) at the front of the unit. Controls and indicators are described in Table 4-1.

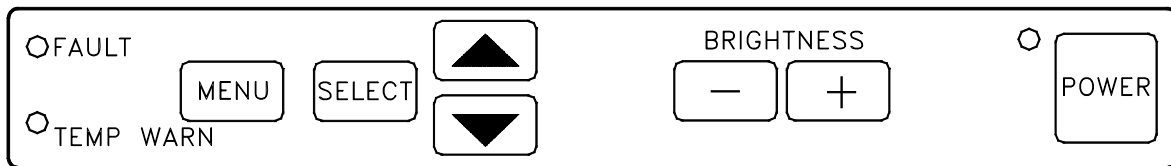

800033-497

**Figure 4-1. Control Panel**

**Table 4-1. Controls and Indicators**

Identification	Description	Function
POWER	Switch and LED	Switch turns monitor prime power on or off. This feature is functional. LED indicates power on/off state.
BRIGHTNESS	Switches	Increase (+) or decrease (-) the backlight intensity and the user settings.
Up/Down Arrow	Switches	Used to change values associated with the selection of setup options.
MENU	Switch	Used to invoke the setup and adjustment program and scroll through menu options.
SELECT	Switch	This switch is non-functional.
FAULT	LED	Indicates that video input signals are outside of the acceptable frequency range.
TEMP WARN	LED	Indicates that temperature within the monitor is not within the acceptable operating range. LED blinks when the heater is active.



### 4.3 Power Up

Monitor power is ready as soon as prime power is applied to the unit. The POWER button is functional. Verify that the power indicator is illuminated. Under normal operating conditions, the FAULT and TEMP WARN indicators should not be illuminated.

### 4.4 Setup

The Model 5500 monitor examines the incoming signal at startup and automatically displays the video image in its proper format. This eliminates the need for adjustments to most video sources. To run the setup program, press the MENU key and the Main Menu will appear. Once the Main Menu appears, use the MENU key to the Video Select Menu. Once you are in the Utility Menu, press the Up Arrow/Down Arrow to select the input video signal.

#### 4.4.1 Image Adjustment

To compensate for user preferences and differences in video signals from one source to another, the Model 5500 monitor provides the user with the means for adjusting various display parameters. The MENU and up/down arrow keys shown in Figure 4-1 allow the user to perform display adjustments.

#### 4.4.2 Navigating Menus

There are numerous adjustments that can be made once the Main Menu has been selected. To obtain the Main Menu, press the MENU key once. The MENU key is used to scroll through the available menu selections. A highlighted feature is selected for adjustment. The up arrow is used to invoke a selected menu item. Once an individual item is selected, the “+” and “-“ keys are used to adjust the feature. The menu background can be set to blue or opaque in the Utilities Menu. Blue is easier to read when displaying computer data and opaque is preferred for live video.

#### 4.4.3 On Screen Display Menus

Press the MENU button to enter the user interface and activate the On Screen Display (OSD).

**Main Menu**

<b>Brightness and Contrast</b>	<b>Color Temperature</b>	<b>Frequency and Phase</b>	<b>Status</b>	<b>Position</b>	<b>Picture in Picture</b>
<b>Graphic Scaling Modes</b>	<b>Language</b>	<b>Video Source</b>	<b>Utilities</b>	<b>Volume</b>	<b>Exit</b>

#### 4.4.3.1 Brightness and Contrast

The Brightness adjustment is used to change the apparent brightness of the display image. Note that a significant increase or decrease in this setting can reduce the amount of visible grayscales. It is preferred to change the backlight brightness by using the BRIGHTNESS +/- keys on the control panel.

The Contrast adjustment increases the black level of the display image. Black and gray images are made darker or lighter with this adjustment. If contrast is too low or high, the image will appear to have lost grayscales.

Brightness and Contrast Menu	
<b>Brightness:</b>	Adjust the panel brightness level
<b>Contrast:</b>	Adjust the panel contrast level

#### 4.4.3.2 Color Temperature

The Color Temperature adjustment feature allows the intensity of white to be changed. The color temperature is a predetermined value selected from a table of four gain adjustments programmed at the factory. Use the setting that provides the best balance of colors.

Color Temperature Menu				
<b>Color Temperature:</b>	9500K	8000K	6500K	5000K

#### 4.4.3.3 Frequency and Phase

The Frequency adjustment expands or contracts the horizontal size of the displayed image. The number displayed is a function of the number of clocks in the analog video input per horizontal sync signal. This adjustment is factory set for compliance with VESA standards. If the video source signal varies from the VESA standard, the displayed image may be too wide or narrow and vertical banding or character jitter will appear in gray and light colors.

The Phase adjustment fine-tunes the phase relationship of the dot-clock and data. The focus may require adjustment if there is character jitter, ghosting, or characters do not appear sharp.

Frequency and Phase Menu	
<b>Frequency:</b>	Adjust the image horizontal size
<b>Phase:</b>	Fine Tune the data sampling position
<b>Picture Type:</b>	Motion, Still

**4.4.3.4 Status**

The status menu displays the graphic information for resolution and frequency of the video source.

<b>Status Menu</b>		
	<b>Horizontal</b>	<b>Vertical</b>
<b>Resolution:</b>	<b>1280</b>	<b>1024</b>
<b>Frequency:</b>	<b>63.9 KHz</b>	<b>60 Hz</b>

**4.4.3.5 Position**

The position menu allows the user to adjust the image horizontally and vertically.

<b>Position Menu</b>
<b>Image up/down: adjust using the up/down arrows</b>
<b>Image left/right: adjust using the +/- buttons</b>

**4.4.3.6 Picture in Picture Menu**

If the system installation supports live video, computer data and camera or video player images can be displayed simultaneously. Note that computer data cannot overlay video and that two live video sources cannot be displayed simultaneously. The following options are displayed when the Picture-in-Picture (PIP) Menu is selected from the Main Menu.

<b>Picture in Picture Menu</b>				
<b>PIP Size:</b>	<b>Off</b>	<b>1</b>	<b>2</b>	<b>3</b>
<b>PIP Source:</b>	<b>Auto</b>	<b>Composite</b>	<b>SVideo</b>	<b>YCbCr/RGB</b>
<b>Horizontal Position:</b>	<b>adjust the position of the PIP window horizontally</b>			
<b>Vertical Position:</b>	<b>adjust the position of the PIP window vertically</b>			
<b>Advanced Settings:</b>				
<b>Brightness:</b>	<b>adjust the image brightness of the PIP window</b>			
<b>Contrast:</b>	<b>adjust the image contrast of the PIP window</b>			
<b>Sharpness:</b>	<b>adjust the image sharpness of the PIP window</b>			
<b>Tint:</b>	<b>adjust the image tint of the PIP window</b>			
<b>Color:</b>	<b>adjust the image color of the PIP window</b>			

**4.4.3.6.1 PIP Size**

To enable PIP, select the preferred size (1, 2, 3) and a picture window of 320 x 240 resolution will be displayed. The window size is variable, but the resolution is fixed.

**4.4.3.6.2 PIP Source**

Different PIP video sources may be selected. If Auto is selected, the monitor will display composite, s-video or component video when active. The user can also manually select the PIP video source as composite, s-video, and component.

#### 4.4.3.6.3 Horizontal Position

The horizontal adjustment feature allows the PIP to be relocated to any position on the screen. Use the +/- buttons to move the image left or right. The down arrow is used to toggle between vertical and horizontal modes.

#### 4.4.3.6.4 Vertical Position

The vertical adjustment feature allows the PIP to be relocated to any position on the screen. Use the +/- buttons to move the image up or down. The down arrow is used to toggle between vertical and horizontal modes.

#### 4.4.3.6.5 Advanced PIP Settings

The advanced settings allow the PIP image window to be adjusted for brightness, contrast, sharpness, tint, and color. The up and down arrow keys is used to toggle between the settings. The +/- buttons are used to adjust the setting.

#### 4.4.3.7 Graphic Scaling Modes

The graphic scaling modes allow the user to select the scalar mode for the graphic image. Use the up / down arrows to select a scalar mode. Use the +/- buttons to adjust the scalar settings.

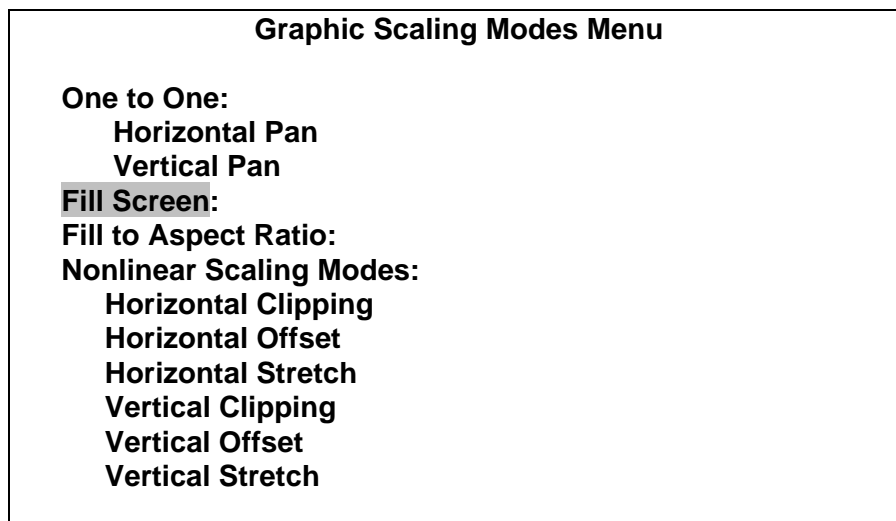

##### 4.4.3.7.1 One to One

The One to One setting displays the image resolution to the graphic resolution. Use the horizontal and vertical pan then adjust the graphic location of the 1:1 image.

##### 4.4.3.7.2 Fill Screen

The full screen setting allows the user to display the lower resolution image to the full screen.

##### 4.4.3.7.3 Fill to Aspect Ratio

The full to aspect ratio setting allows the user to display the lower resolution image to the screen aspect ratio.

**4.4.3.7.4 Nonlinear Scaling Mode**

The nonlinear scaling mode allows the user to custom select any scaling size using the horizontal clip, offset and stretch and the vertical clip, offset and stretch.

**4.4.3.8 Language Menu**

The OSD can be displayed in one of three languages. English is the default.

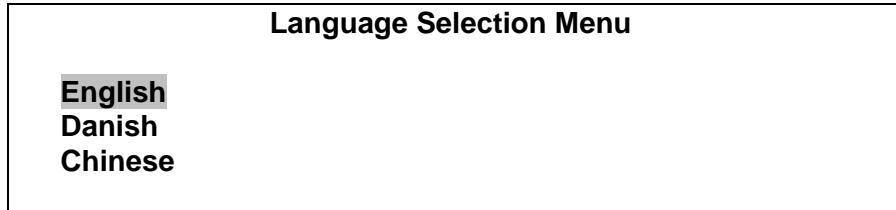

**4.4.3.9 Video Source**

The video source allows the user to select the input video signal. There is also an auto-sync function that is activated by pressing the “-“ button.

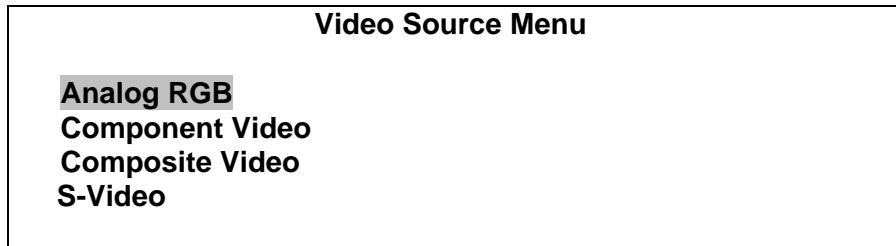

**4.4.3.10 Utilities**

The following options are displayed when the Utilities Menu is selected from the Main Menu

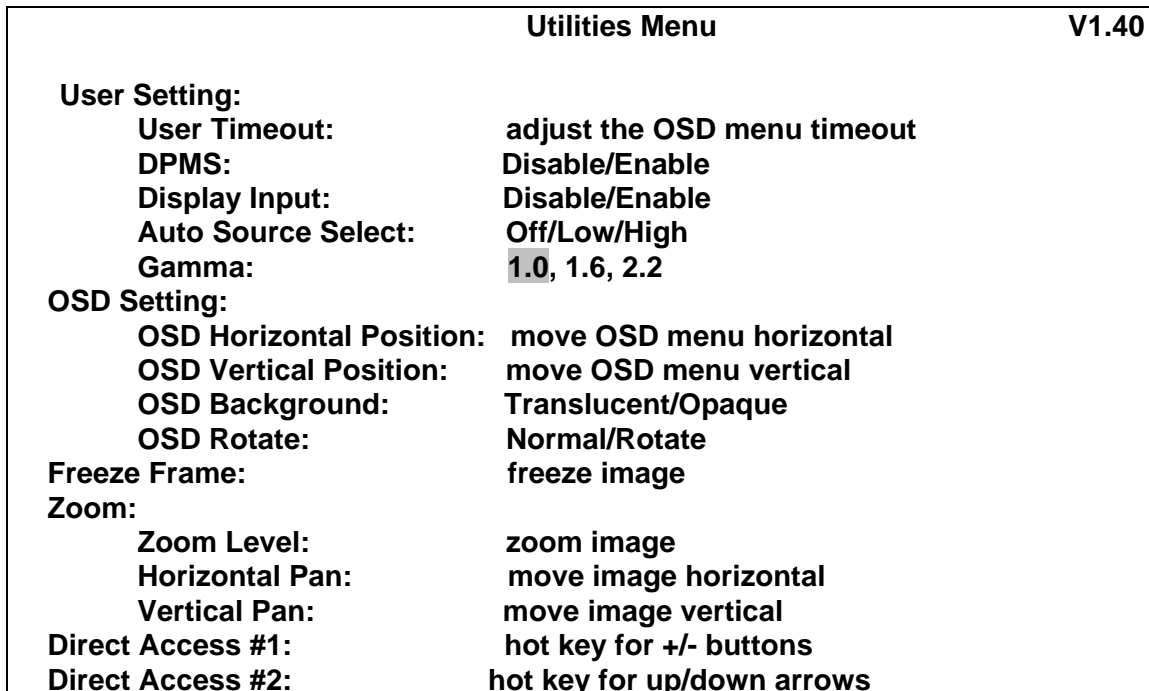

<b>Display Orientation:</b>	<b>Normal, Horz Inverse, Vert Inverse, Inverse</b>
<b>Calibrate RGB Gain:</b>	<b>Color Calibration</b>
<b>Load Factory Defaults:</b>	<b>Recall factory defaults</b>

#### 4.4.3.10.1 User Setting

##### 4.4.3.10.1.1 Display Timeout

Adjust the OSD menu timeout period in steps of 5 seconds from 5 to 50 seconds.

##### 4.4.3.10.1.2 DPMS

The user can enable the DPMS (Display Power Management Signaling), which is a power save mode. The monitor will go into a standby state when there is no keyboard or mouse activity. The DPMS is setup in the host computer for the timeout length. The DPMS mode will turn off the sync signal to the monitor, which will turn off the inverter and the LCD backlights.

##### 4.4.3.10.1.3 Display Input

This feature displays an information window in the top left of the monitor and contains the video source. The window is enabled as a default but can be disabled.

##### 4.4.3.10.1.4 Auto Source Select

The Auto Source Select feature is used to control the video source that is displayed on power-up. The controller will always display the source that was selected when the unit was last powered down. If Auto Source is enabled when the unit is powered up and the source previously used is not present, the display will search for the next available input source. If Auto Source is disabled and the source previously used is not present, the display will not search for another input source. In the latter scenario, a blue screen will be displayed.

##### 4.4.3.10.1.5 Gamma

The gamma setting is a feature to adjust the color balance. There are three selectable settings and the user may choose the best setting. The default is the 1.0 setting.

#### 4.4.3.10.2 OSD Setting

##### 4.4.3.10.2.1 OSD Horizontal and Vertical Position

The horizontal and vertical position adjustment allows the On Screen Display (OSD) to be relocated to any position on the screen. Use the up arrow to move the image up or to the right. The image is shifted down or left using the down arrow key. The MENU switch is used to toggle the arrows between vertical and horizontal modes.

##### 4.4.3.10.2.2 OSD Background

The OSD Background adjustment feature allows the background color of the OSD to be set to blue or opaque. It is recommended that blue be used for computer data and opaque for live data.

##### 4.4.3.10.2.3 OSD Rotate

The user can rotate the OSD 90 degrees counter clockwise (CCW) by selecting the rotate adjustment.

#### 4.4.3.10.3 Freeze Frame

Freeze the image using the “+” button and press the “+” button again to unfreeze the image.

#### 4.4.3.10.4 Zoom

This function allows the user to zoom on the displayed image. Use the “+” button to zoom in the image and the “-” button to zoom out the image.

The horizontal and vertical pan will move the zoomed image in the horizontal and vertical directions.

#### 4.4.3.10.5 Direct Access #1

The user can define the functionality of the +/- buttons to adjust: Brightness, Contrast, Volume, Freeze, Zoom, Video Source (sequencing of Analog RGB, Composite Video, S-Video, Component Video), PIP.

#### 4.4.3.10.6 Direct Access #2

The user can define the functionality of the up/down arrow buttons to adjust: Brightness, Contrast, Volume, Freeze, Zoom, Video Source (sequencing of Analog RGB, Composite Video, S-Video, Component Video), PIP.

#### 4.4.3.10.7 Display Orientation

This function allows the user to select between Normal, Horizontal Inverse, Vertical Inverse, and Inverse.

#### 4.4.3.10.8 Calibrate RGB Gain

This allows the user to initiate an automatic color calibration. Press the “+” button to calibrate.

#### 4.4.3.10.9 Load Factory Defaults

Recall the factory defaults. This will return all users’ personal settings back to the factory settings.

#### 4.4.3.11 Volume

This function is not available.

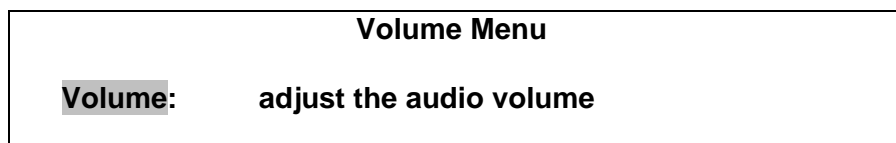

#### 4.4.3.12 Exit

Use the +/- buttons to exit.

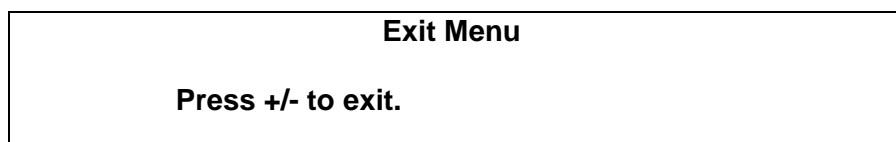

## 5 FUNCTIONAL DESCRIPTION

### 5.1 Introduction

This chapter describes the major functional elements of the Model 5500 Color Monitor. Information is provided concerning power distribution, the video display system, control panel, temperature monitoring and heater subsystem, and optional features. Chassis interconnections are identified in Figure 5-1. Model 5500 functional elements are described in the following paragraphs.

#### 5.1.1 Power Distribution

Prime power enters the chassis at the power connector on the rear panel (Figure 3-2). An EMI filter provides attenuation of interference related to input voltage and output current. Prime power exits the filter and is routed to a circuit breaker. The load side of the circuit breaker provides power to the +12 V and +48 V power supplies. The output of the +12 V supply is sent to the breakout circuit board and distributed throughout the display subsystem. Exclusively the heater panel uses the +48 V power supply output.

#### 5.1.2 Video Display System

##### 5.1.2.1 Display Controller

The Model 5500 monitor incorporates an active matrix color thin-film transistor (TFT) display controller. The controller supports analog RGB/sync-on-green input signal format with resolutions of 640 x 480 to 1280 x 1024 pixels at 56 to 85 Hz. VESA, NTSC, S-Video and PAL operation is supported with 262K to 16.7M colors.

##### 5.1.2.2 LVDS Board

The Low Voltage Differential Signaling (LVDS) board converts the display controller output signal to the format required by the display panel.

##### 5.1.2.3 Display Panel

The Model 5500 monitor utilizes an active color matrix liquid crystal display (LCD) with an integral cold cathode fluorescent tube backlight system. It is a transmissive display that operates normally in black mode. The panel has an 19-inch (diagonal) display area with SXGA resolution of 1280 x 1024 pixels. Each pixel is divided into red, green, and blue sub-pixels or dots that are arranged in vertical stripes. Grayscale or the brightness of a sub-pixel color is determined with an 8-bit grayscale signal for each dot, which provides a palette exceeding 16 million colors.

##### 5.1.2.4 Inverter

A cold-cathode fluorescent lamp inverter is used to drive the LCD backlight lamps of the display panel. The inverter uses a fixed lamp current with duty-cycle control. The lamp current burst is modulated from 2 to 100%, which allows the display to be dimmed to 1% of full brightness.



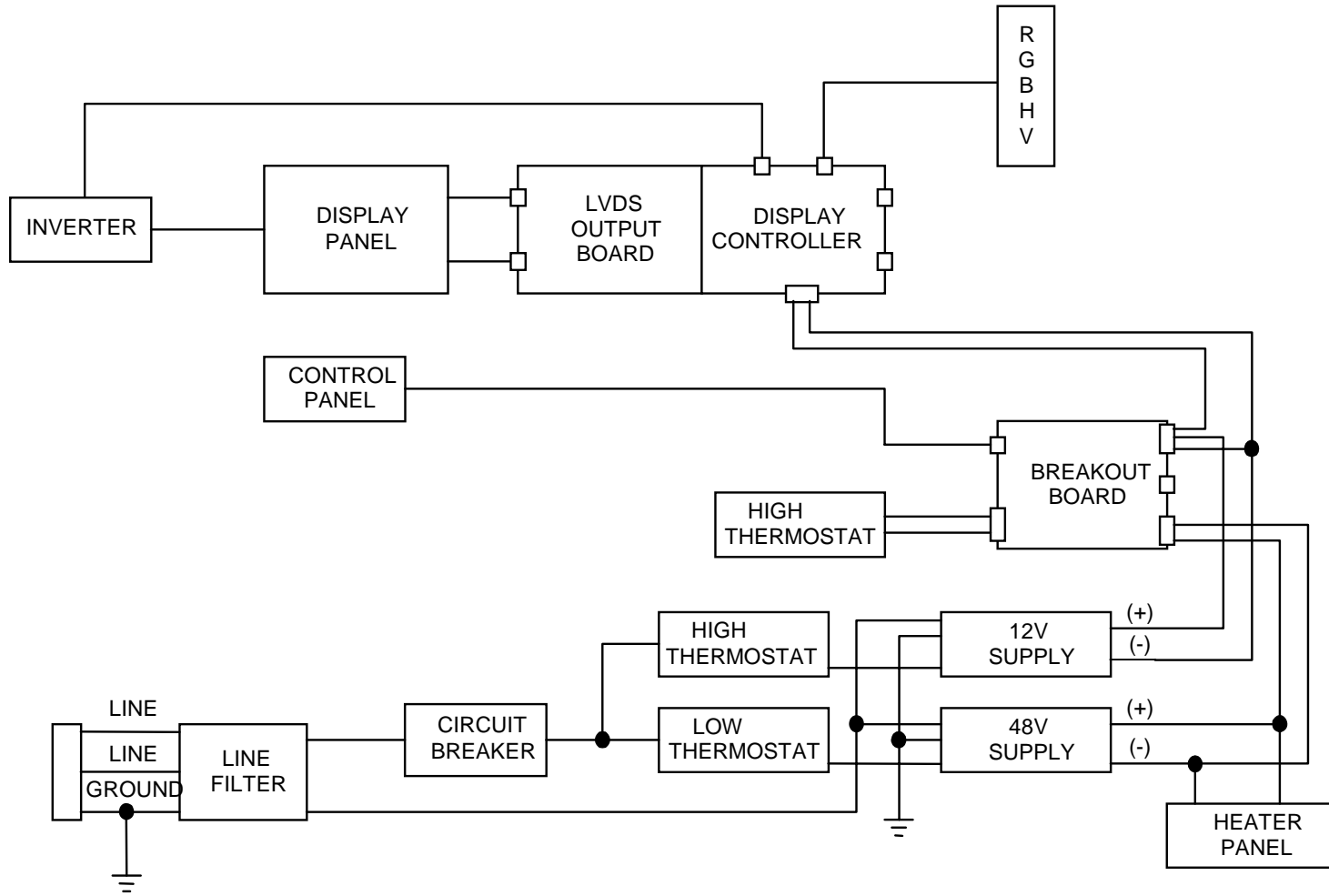

Figure 5-1. Chassis Interconnections

### **5.1.3 Control Panel**

The control panel provides the user interface for performing the display controller set up and configuration functions described in Chapter 4. The +/- switches on the panel adjust the backlight intensity of the display panel.

### **5.1.4 Fault Monitoring and Heater Subsystem**

The Model 5500 monitor incorporates three thermostat switches that prevent the unit from operating at temperatures that could damage internal components. If temperature within the monitor chassis reaches 60°C, the control panel TEMP WARN indicator illuminates. If temperature reaches 71°C, the main (+12 V) power supply is shut down. The display panel heater is active whenever internal temperature is 10°C or below. The TEMP WARN indicator blinks when the heater is active.

### **5.1.5 Optional Features**

Optional features available for the Model 5500 monitor are described in the following paragraphs. Refer to Chapter 1 for a description of options included with the delivered configuration.

#### **5.1.5.1 Input Power**

The Model 5500 monitor support ac input power. The ac input power configuration operates within a range of 85 to 265 Vac at 47 to 440 Hz.

#### **5.1.5.2 Single-Pole Circuit Breaker**

The Model 5500 monitor is configured with a single-pole circuit breaker.

## 6 MAINTENANCE

### 6.1 Introduction

This chapter provides information and instructions concerning Model 5500 tools and support equipment, periodic maintenance, troubleshooting, and storage/transportation considerations.

### 6.2 Tools and Support Equipment

The following tools and support equipment are required to maintain the Model 5500 monitor:

- Common hand tools
- Digital multimeter
- Host computer with a compatible video interface

### 6.3 Periodic Maintenance

#### 6.3.1 Display Adjustments

It may become necessary to repeat the monitor set up and configuration process after prolonged use or a change in the host video source. Adjustment procedures are identified in Chapter 4.

#### 6.3.2 Cleaning

The display faceplate of the monitor can be cleaned with common glass cleaner and a lint-free cloth. Do not use harsh chemicals or abrasive material to clean the glass.

### 6.4 Troubleshooting

If operational problems remain after the adjustment procedures identified in Chapter 4 have been performed, refer to the troubleshooting information provided in Table 6-1.

#### WARNING

THE MONITOR ENCLOSURE MUST NOT BE OPENED FOR ANY FAULT ISOLATION ACTIVITY. EXTERNAL VOLTAGE OR SIGNAL MEASUREMENTS MUST ONLY BE OBTAINED USING THE APPROPRIATE TEST EQUIPMENT.

### 6.5 Storage and Transportation

If the monitor chassis is to be stored or transported, the unit should be packaged as originally shipped. The monitor can be stored or transported in any manner that is consistent with the environmental conditions identified in Table 2-4. The fluorescent tube in the monitor backlight assembly contains mercury. If monitor shipment or disposal is required, observe the applicable guidelines relating to the handling of this substance.

**Table 6-1. Troubleshooting**

Condition	Recommended Action
Monitor will not power up when control panel POWER switch is activated.	Verify that input power is within the limits defined in Table 2-2 for the applicable input power configuration. Ensure that the circuit breaker is depressed.
Monitor POWER LED is illuminated, but display is inactive.	Check that all video cables are correctly connected. Cycle monitor power. If the problem remains, connect the monitor to a known good host video source to determine if the problem lies with the monitor or computer.
A color is missing from the test pattern.	Replace the external video cable.
Image size is too large for the screen.	Setup the Fill to Screen procedure in the Utility Menu.
Characters are ghosting.	Set the vertical refresh rate to 60 Hz. Replace the external video cable.
Text is too small.	Verify that the monitor resolution setting matches that of the computer data. Refer to the Graphics Mode function at the Main Menu.
Character jitter.	Adjust the frequency and phase settings in the Main Menu. When using a Windows operating system, it is helpful to perform this adjustment with the shutdown screen (Start_Shutdown) in the background.
Black or blue square appears on the screen.	From the Picture in Picture Menu, determine if the PIP feature is enabled. If there is no PIP video source, disable the feature.
Monitor adjustments are in an unknown state.	Restore factory default settings from the Utility Menu.